



2N[®] IP Solo

IP Intercom



Installation Manual

Version: 2.16

www.2n.cz

The 2N TELEKOMUNIKACE a.s. is a Czech manufacturer and supplier of telecommunications equipment.



The product family developed by 2N TELEKOMUNIKACE a.s. includes GSM gateways, private branch exchanges (PBX), and door and lift communicators. 2N TELEKOMUNIKACE a.s. has been ranked among the Czech top companies for years and represented a symbol of stability and prosperity on the telecommunications market for almost two decades. At present, we export our products into over 120 countries worldwide and have exclusive distributors on all continents.



2N[®] is a registered trademark of 2N TELEKOMUNIKACE a.s. Any product and/or other names mentioned herein are registered trademarks and/or trademarks or brands protected by law.



2N TELEKOMUNIKACE a.s. administers the FAQ database to help you quickly find information and to answer your questions about 2N products and services. On www.faq.2n.cz you can find information regarding products adjustment and instructions for optimum use and procedures „What to do if...“.



2N TELEKOMUNIKACE a.s. hereby declares that the 2N product complies with all basic requirements and other relevant provisions of the 1999/5/EC directive. For the full wording of the Declaration of Conformity see the CD-ROM (if enclosed) or our website at www.2n.cz.



This device complies with part 15 of the FCC Rules. Operation is subject to the following two conditions: (1) This device may not cause harmful interference, and (2) this device must accept any interference received, including interference that may cause undesired operation.



The 2N TELEKOMUNIKACE a.s. is the holder of the ISO 9001:2009 certificate. All development, production and distribution processes of the company are managed by this standard and guarantee a high quality, technical level and professional aspect of all our products.

Content:

- 1. Product Overview
 - 1.1 Components and Associated Products
 - 1.2 Terms and Symbols
- 2. Description and Installation
 - 2.1 Before You Start
 - 2.2 Mechanical Installation
 - 2.2.1 Main Unit Mounting
 - 2.3 Electric Installation
 - 2.3.1 Overvoltage Protection
 - 2.4 Extending Module Connection
 - 2.5 Completion
- 3. Function and Use
 - 3.1 Configuration
 - 3.2 Intercom Control as Viewed by External User
 - 3.3 Intercom Control as Viewed by Internal User
 - 3.4 Maintenance
 - 3.5 Downloads
- 4. Technical Parameters
 - 4.1 General drawings
- 5. Supplementary Information
 - 5.1 Troubleshooting
 - 5.2 Directives, Laws and Regulations
 - 5.3 General Instructions and Cautions

1. Product Overview

Here is what you can find in this section:

- 1.1 Components and Associated Products
- 1.2 Terms and Symbols

Basic Features

2N[®] IP Solo is an elegant and reliable intercom equipped with lots of useful functions. Thanks to SIP support and compatibility with major brands of PBX manufacturers, it can benefit from using VoIP networks. **2N[®] IP Solo** can be used as a door or special purpose intercom for office buildings, residential areas and other applications.

Wide angle HD camera - allows the tenant to see the calling person on his or her videophone or PC screen in high resolution. The camera itself is hidden behind a darkened glass, so it is not visible. The intercom is equipped with night vision, which automatically selects the night/day mode according to light.

Quick dial button - there is 1 quick dial buttons in total. For this button, up to three separate phone numbers plus substitute users can be defined, which ensures that the called user is reached whenever needed. The button is backlit with a clear mechanical response. The nametag surface is scratch resistant.

Electric lock control - as part of the access system, the electrical lock can be controlled by a code entered on the keypad or the called phone, with the RFID card, via a PC application, etc. When necessary, more electrical outputs can be added. Numerous parameters allow for a wide spectrum of applications.

Robustness - **2N[®] IP Solo** is designed as a vandal resistant intercom, which withstands mechanical or weather conditions with no need to purchase extra accessories.

Audio quality - using the automatic echo cancelling system, full duplex communication is available at any time.

The installation of 2N[®] IP Solo is very easy, all you have to do is assemble the required parts and modules and attach the network cable. The modules are plug&play, so there is no need to configure them manually. The intercom can be supplied from a 12 V DC power source, or using a PoE switch.



Use your PC with any internet browser to configure **2N[®] IP Solo** or apply the **2N[®] Access Commander** to configure extensive installations of multiple intercoms.





Advantages of Use

- Elegant design
- Weather resistant
- Various modes of installation (flush, surface, plasterboard)
- Sensitive microphone and loud speaker
- Both-way audio communication – acoustic echo cancellation
- Integrated colour HD camera with wide-angle lense and hidden night vision
- Integrated switches of electric locks with wide setting options
- Optional integrated RFID card reader module
- PoE or 12 V DC power supply
- Configuration using web interface or dedicated PC application
- VoIP standard SIP 2.0 support
- 1999 Phone Book positions
- 20 user time profiles
- Video codecs (H.263, H.263+, H.264, MPEG-4, MJPEG)
- Audio codecs (G.711, G.729, G.722, L16/16kHz)
- HTTP server for configuration
- SNTP client for time synchronisation
- RTSP server for audio and video streaming, ONVIF compatible
- SMTP client for email sending, Picture to Email feature
- TFTP/HTTP client for automated firmware and configuration upgrade and update

1.1 Components and Associated Products

Main Units

<p>2N Part No. 9155301CF Axis Part No. 01300-001</p> 	<ul style="list-style-type: none">• Main unit• Flush mount• HD camera
<p>2N Part No. 9155301F Axis Part No. 02205-001</p> 	<ul style="list-style-type: none">• Main unit• Flush mount• Cameraless version
<p>2N Part No. 9155301CBF Axis Part No. 01303-001</p> 	<ul style="list-style-type: none">• Main unit• Flush mount• HD camera

<p>2N Part No. 9155301BF Axis Part No. 02204-001</p> 	<ul style="list-style-type: none">• Main unit• Flush mount• Cameraless version
<p>2N Part No. 9155301CS Axis Part No. 01301-001</p> 	<ul style="list-style-type: none">• Main unit• Surface mount• HD camera
<p>2N Part No. 9155301S Axis part No. 02203-001</p> 	<ul style="list-style-type: none">• Main unit• Surface mount• Cameraless version
<p>2N Part No. 9155301CBS Axis Part No. 01302-001</p> 	<ul style="list-style-type: none">• Main unit• Surface mount• HD camera

2N Part No. 9155301BS

Axis Part No. 02202-001



- Main unit
- Surface mount
- Cameraless version

Mounting Accessories

2N Part No. 9155017

Axis Part No. 01304-001



- Flush mounting box
- Designed for flush or plasterboard mounting.

2N Part No. 9155068

Axis Part No. 01305-001



- Backplate
- For uneven surface installation

2N Part No. 9155071

Axis Part No. 02077-001



- Wedge backplate
- 25° gradient mounting backplate

2N Part No. 9155074

Axis Part No. 02078-001



- Glass mount
- Remember to use the uneven surface mounting backplate **Part No. 9155068** while installing 2N[®] IP Solo onto a glass surface.

Choose the proper frame and, if necessary, mounting box type depending on your particular 2N[®] IP Solo installation needs. 2N[®] IP Solo is designed for outdoor applications and requires no additional roof.

Internal Units and Accessories

Part Numbers:

2N Part No. 91378375

Axis Part No. 01668-001

2N Part No. 91378376

Axis Part No. 01670-001



- 2N[®] Indoor Touch 2.0 - black
- WiFi version (second Part No.)
- The elegant internal touch panel, 2N[®] Indoor Touch 2.0 , is suitable for all 2N IP intercoms. On the panel's display not only can you find out who is at the door, but also start a conversation with the visitor, open the lock or turn on the light in the entrance hall.

2N Part. No. 91378382

Axis Part No. 01425-001



- 2N[®] Indoor Touch desk stand black



Part Numbers:**2N Part. No. 91378375WH****Axis Part No. 01669-001****2N Part. No. 91378375WH****Axis Part No. 01671-001**

- 2N[®] Indoor Touch 2.0 – white
- WiFi version (second Part no.)
- The elegant internal touch panel, 2N[®] Indoor Touch 2.0, is suitable for all 2N IP intercoms. On the panel's display not only can you find out who is at the door, but also start a conversation with the visitor, open the lock or turn on the light in the entrance hall.



2N Part No. 91378382W**Axis Part No. 01426-001**



- 2N[®] Indoor Touch desk stand white

VoIP Phones

<p>2N Part No. 91378357</p> <p>Axis Part No. 01422-001</p> 	<ul style="list-style-type: none">• Grandstream GXV3240 VoIP video telephone• GXV3240 is the successor to the popular GXV3140 model, which allows comfortable video calls in the IP network. Touchscreen and keyboard control.
<p>2N Part No. 91378358</p> <p>Axis Part No. 01421-001</p> 	<ul style="list-style-type: none">• Grandstream GXV3275 VoIP telephone• GXV3275 is the successor to the popular GXV3175 model, which allows comfortable video calls in the IP network. Touchscreen control.

Electric Locks



<p>Part No. 932071E</p> 	<ul style="list-style-type: none">• BEFO 11211• 12 V / 230 mA DC• low consumption
<p>Part No. 932081E</p> 	<ul style="list-style-type: none">• BEFO 11221 with momentum pin• 12 V / 230 mA DC• low consumption• A short electrical impuls is sufficient for opening the lock. The lock remains open until someone closes the door.
<p>Part No. 932091E</p> 	<ul style="list-style-type: none">• BEFO 11211MB with mechanical blocking• 12 V / 230 mA DC• low consumption• Enables mechanically close or open a lock. Once opened, the lock remains open all the time. Once closed, the lock behaves as a standard electric lock.

<p>Part No. 932061E</p> 	<ul style="list-style-type: none">• BEFO 211211 door signalling, low consumption• 12 V / 230 mA• A regular lock with a built-in contact to indicate whether the door is open or closed.
<p>Part No. 932072E</p> 	<ul style="list-style-type: none">• BEFO 31211• fail-safe• 12 V / 170 mA DC• The failsafe lock is closed when electricity is switched on. When electricity is interrupted, the lock is opened.
<p>Part No. 932062E</p> 	<ul style="list-style-type: none">• BEFO 321211• fail-safe, door signalling• 12 V / 170 mA• The failsafe lock is closed when electricity is switched on. When electricity is interrupted, the lock is opened.• It contains a built-in contact to indicate whether the door is open or closed.

✔ **Tip**

- FAQ: Electric locks - Difference between locks in 2N IP intercoms accessories

Power Supply

<p>Part Numbers:</p> <p>2N Part No. 91378100E</p> <p>2N Part No. 91378100US</p> <p>Axis Part No. 01394-001</p> 	<ul style="list-style-type: none"> • PoE injector - with EU cable • PoE injector - with US cable • For intercom power supply via an Ethernet cable where the PoE switch is unavailable.
<p>Part No. 91341481E</p> 	<ul style="list-style-type: none"> • Stabilised 12 V / 2 A power supply needs to be used where no PoE is available.
<p>Part No. 932928</p> 	<ul style="list-style-type: none"> • 12 V transformer • For 230 V mains voltage. • For external power supply of the lock with 12 V AC voltage.

Two-Wire Connection

2N Part No. 9159014EU/UK

2N Part No. 9159014US

Axis Part No. 01404-001



- 2N[®] 2Wire
 - (set of 2 adapters and power source for EU/US/UK)
 - The 2N[®] 2Wire converter allows you to use the existing wiring (2 wires) from your original door bell or door intercom to connect any IP device. No configuration is necessary, all you need is one 2N[®] 2Wire unit at each end of the cable and a power source connected to at least one of these units.
- The 2N[®] 2Wire unit then provides PoE power not only to the second converter, but also to all the other connected IP end devices.

External Switches

<p>2N Part No. 9159010 Axis Part No. 01386-001</p> 	<ul style="list-style-type: none"> • 2N[®] Security Relay • A handy add-on that significantly enhances door entry security as it prevents tampering with the intercom and forced unlocking. To be installed between the intercom and lock, powered by the intercom.
<p>2N Part No. 9137410E Axis Part No. 01397-001</p> 	<ul style="list-style-type: none"> • External IP Relay - 1 output • Standalone IP device which can be controlled by HTTP commands sent by the 2N IP intercom, which can thus control devices via an unlimited distance.
<p>2N Part No. 9137411E Axis Part No. 01398-001</p> 	<ul style="list-style-type: none"> • External IP Relay - 4 outputs, PoE • Standalone IP device which can be controlled by HTTP commands sent by the 2N IP intercom, which can thus control devices via an unlimited distance.

Sensors and Switches

Part No. 9159013



- Exit button
- A logic input connecting button for door opening inside a building.

2N Part No. 9159012

Axis Part No. 01388-001



- Magnetic door contact
- Designed for door installation to indicate the door opening status. Used when the intercom is used for door protection, to detect whether the door is open or broken.

License

2N Part No. 9137905 Axis Part No. 01376-001	<ul style="list-style-type: none">• Enhanced Audio
2N Part No. 9137906 Axis Part No. 01377-001	<ul style="list-style-type: none">• Enhanced Video
2N Part No. 9137907 Axis Part No. 01378-001	<ul style="list-style-type: none">• Enhanced Integration
2N Part No. 9137908 Axis Part No. 01379-001	<ul style="list-style-type: none">• Enhanced Security
2N Part No. 9137909 Axis Part No. 01380-001	<ul style="list-style-type: none">• Gold
2N Part No. 9137910 Axis Part No. 01381-001	<ul style="list-style-type: none">• InformaCast
2N Part No. 9137915 Axis Part No. 01382-001	<ul style="list-style-type: none">• NFC

Tip

- Refer to the Configuration Manual for 2N IP intercoms, Subs. **3.2 Function Licensing** for details.

1.2 Terms and Symbols

The following symbols and pictograms are used in the manual:

Safety

- Always abide by this information to prevent persons from injury.

Warning

- Always abide by this information to prevent damage to the device.

Caution

- Important information for system functionality.

Tip

- Useful information for quick and efficient functionality.

Note

- Routines or advice for efficient use of the device.

2. Description and Installation

Here is what you can find in this section:

- 2.1 Before You Start
- 2.2 Mechanical Installation
- 2.3 Electric Installation
- 2.4 Extending Module Connection
- 2.5 Completion

2.1 Before You Start

Product Completeness Check

Before you start please check whether the contents of the package of your new 2N[®] IP Solo complies with the following list.

- 1x 2N[®] IP Solo

Surface installation

- Installation manual
- 1x frame for surface installation
- frame holder set
- 3x dowels
- 3x screws
- 1x hex key
- 1x transparent name plate foil

Flush installation

- Installation manual
- 1x frame for flush installation
- frame holder set
- 4x screws
- 1x hex key
- 1x transparent name plate foil

2.2 Mechanical Installation

Mounting Types Overview

Refer to the table below for a list of mounting types and necessary components. You can assemble multiple units in all mounting types.

Flush mounting - classic bricks

- incl. hollow bricks, thermally insulated walls, etc.

What you need for mounting:

- a properly cut hole as instructed in the box package
- plaster, mounting glue, mounting foam or mortar as necessary
- 2N[®] IP Solo, flush mounting boxes (Part No. 9155017)

Flush mounting - plasterboard

What you need for mounting:

- a properly cut hole as instructed in the box package
- 2N[®] IP Solo, flush mounting boxes (Part No. 9155017)



Surface mounting

- concrete and steel structures, entry barrier columns, interior, etc.

What you need for mounting:

- 2N[®] IP Solo

We recommend you to use a mounting backplate, Part No. **9155068**, for uneven surfaces.



Glass mounting

- glass surface

What you need for mounting:

- 2N[®] IP Solo, glass mounting backplate (Part No. **9155074**)



 **Caution**

- The warranty does not apply to the product defects and failures arisen as a result of improper mounting (in contradiction herewith). The manufacturer is neither liable for damage caused by theft within an area that is accessible after the attached electric lock is switched. The product is not designed as a burglar protection device except when used in combination with a standard lock, which has the security function.
- When the proper mounting instructions are not met, water might get in and destroy the electronics. It is because the communicator circuits are under continuous voltage and water infiltration causes an electro-chemical reaction. The manufacturer's warranty shall be void for products damaged in this way!
- Do not remove the plastic foil on the inner frame seal to avoid water infiltration and electronic destruction.

General Mounting Principles

 **Tip**

- Select flush mounting where possible to make your product elegant looking, more vandal resistant and more secure.
- You are advised to buy the flush mounting boxes in advance and commission your building company to do the masonry for you. This approach helps you put your intercom exactly in the vertical position.

 **Caution**

- Before starting the mechanical installation on a selected place, make sure carefully that the preparations connected with it (drilling, wall cutting) cannot damage the electrical, gas, water and other existing wires and pipes.
- Make sure that the diameter of the dowel holes is accurate to avoid falling out of the dowels! Use the mounting glue to secure the dowels if necessary.
- Make sure that the depth of the dowel holes is accurate!
- Do not use low-quality dowels to avoid their pulling out of the wall!
- Having removed the front panel, make sure that no dirt gets inside the product (especially onto the sealing surface).
- Never turn **2N[®] IP Solo** to align the box assembly after mounting. Make sure that the flush mounting boxes have been installed accurately.
- Check the plasterboard wall and room interior pressure values. If the difference between the values is too great (as a result, e.g., of overpressure ventilation), separate the intercom using, for example, the mounting box enclosed and seal the cable passage to avoid speaker damage.
- Surface mounting may cause problems on places exposed to potential vandalism (such as public garages, etc.). In this case, use steel anchoring elements instead of the dowels and screws included in the delivery.
- The place for surface mounting must be flat with maximum inequality of 0.5 mm. (e.g. desk materials, glass, cutted stone etc). If the place is not flat, use flush mounting, backplate **Part No. 9155068** or equal the wall surface.

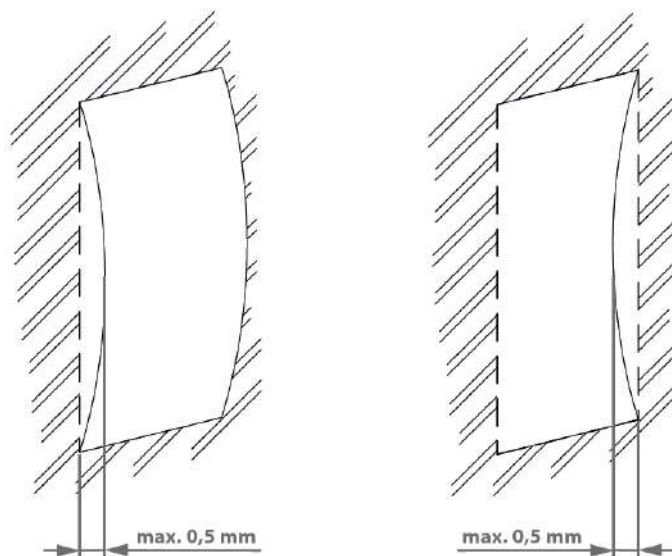

! Safety

- Eliminate the risk of personal injury! Surface mounting is not recommended for narrow passages or places where people's attention is distracted by something else. The manufacturer shall not be liable for injuries in such cases!

Module Installation

- 2.2.1 Main Unit Mounting

2.2.1 Main Unit Mounting

Flush mounting - classic bricks and plasterboard

min 108(W) x 136(H) x 45(D) mm
(min 4,25(W) x 5,35(H) x 1,77(D) in)

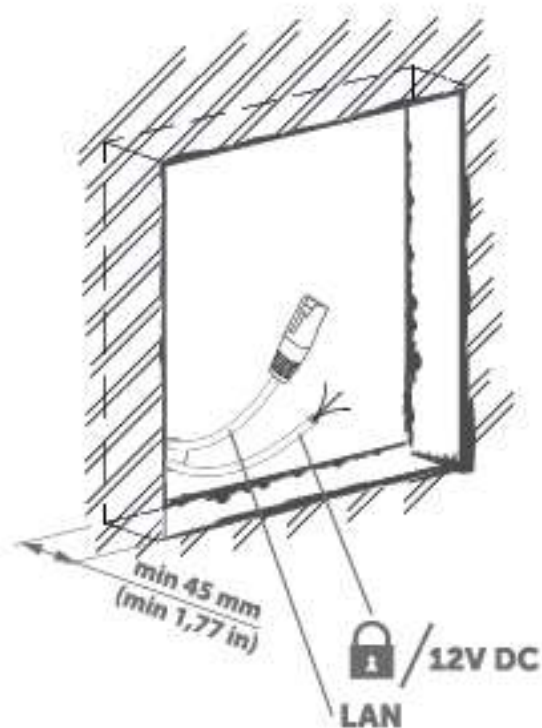
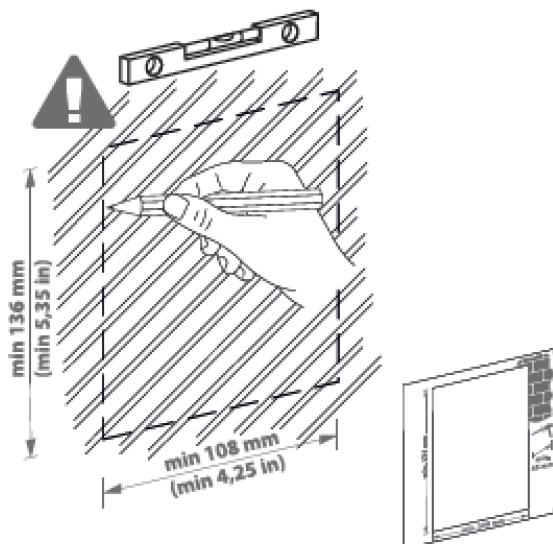

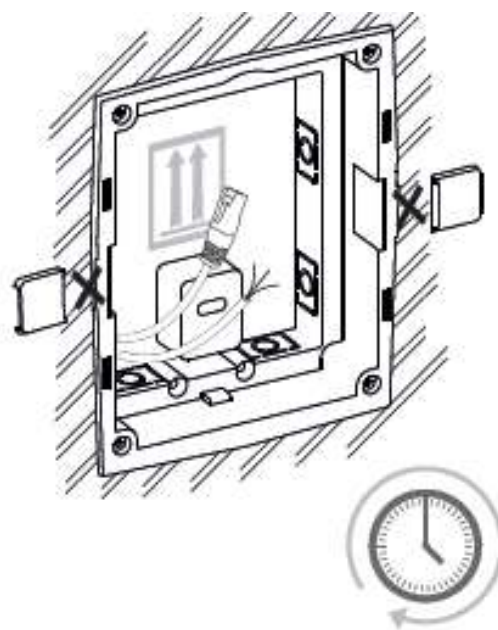
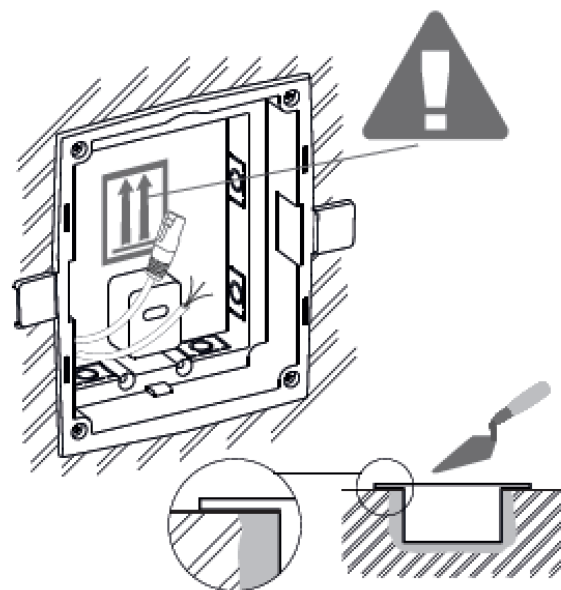

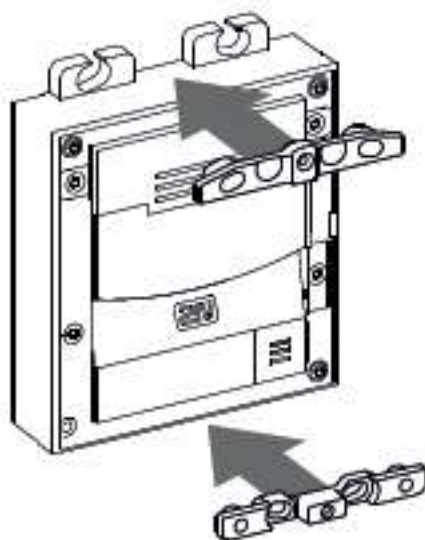
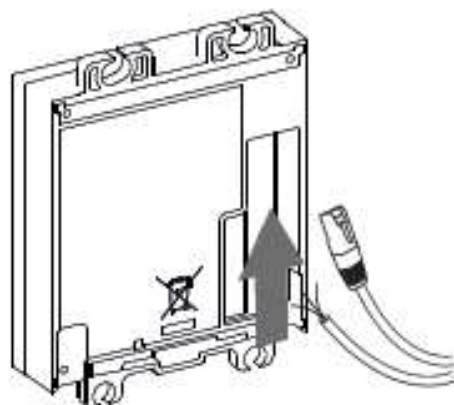

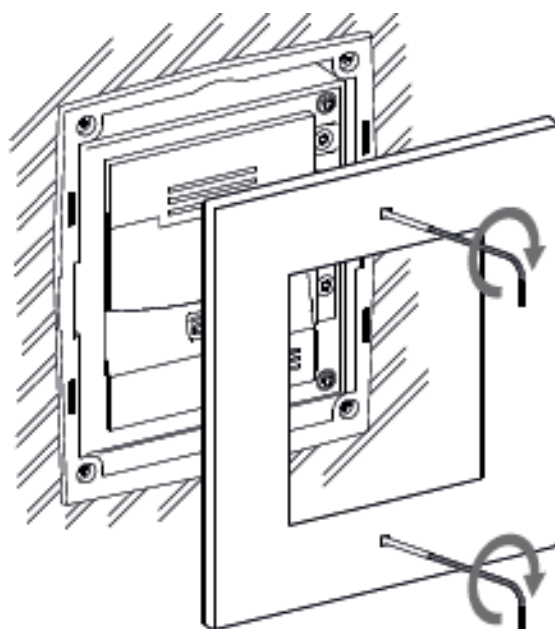
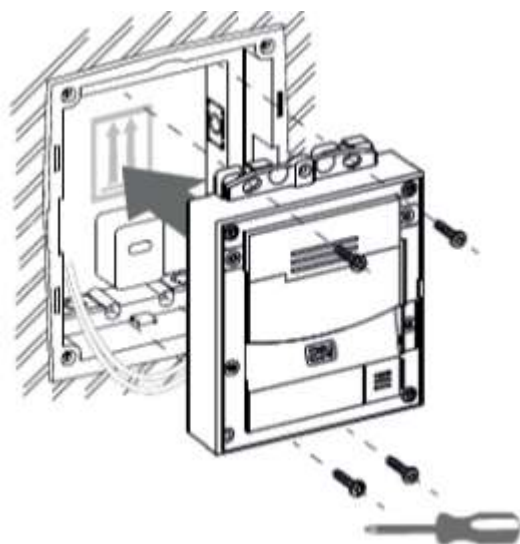

Wall (surface) mounting

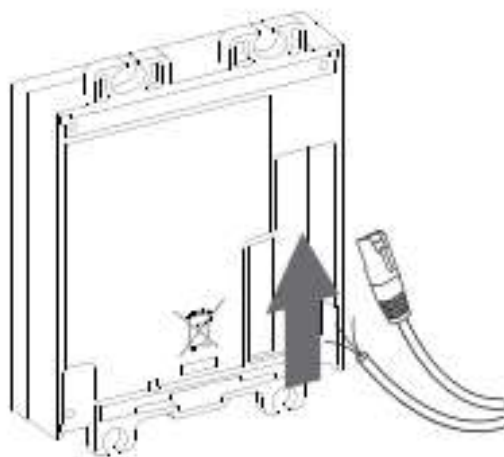
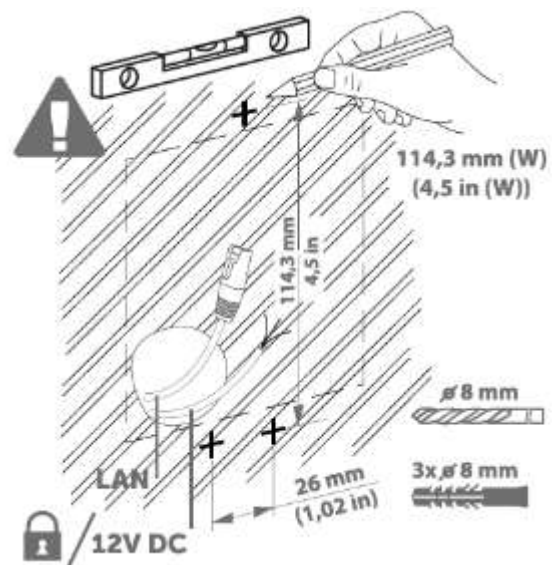

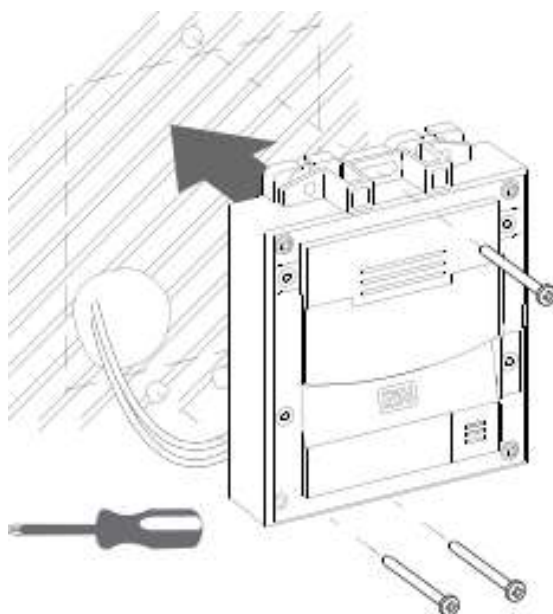
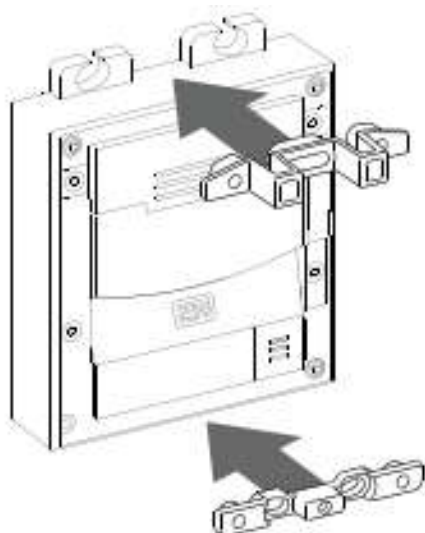

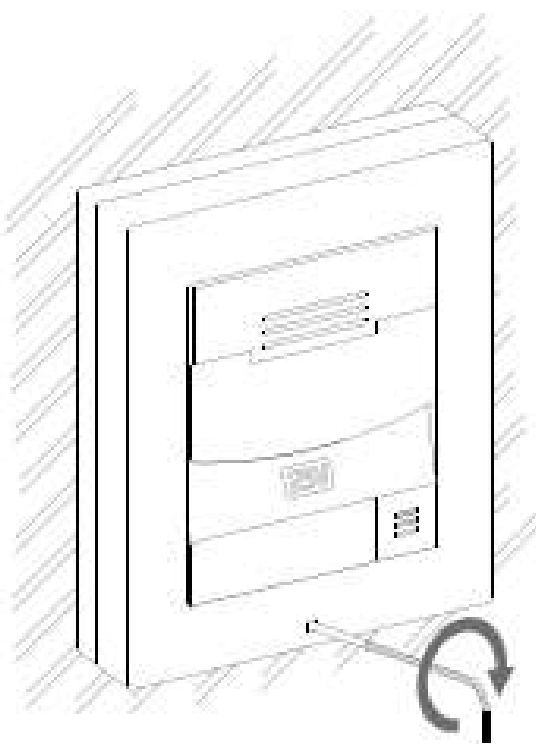
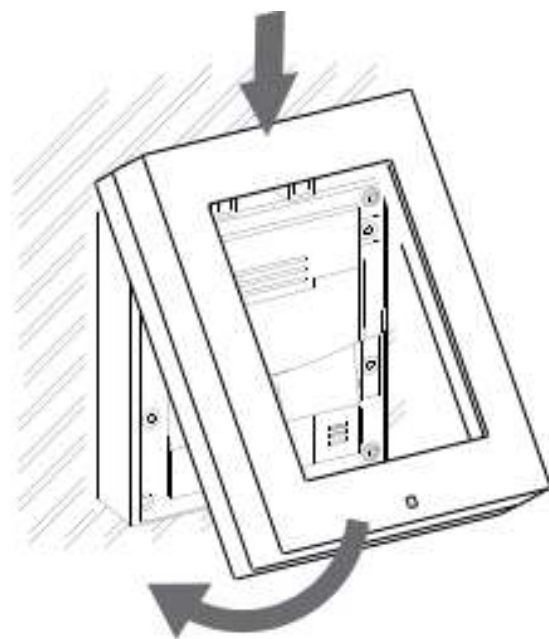

Wall (surface) mounting using backplate

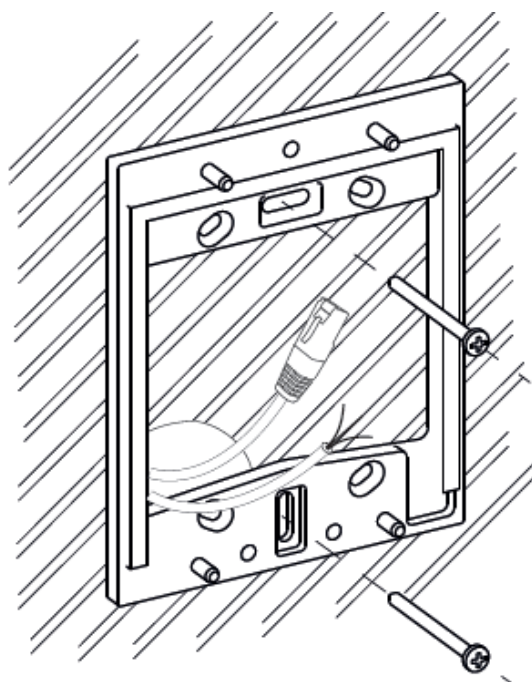
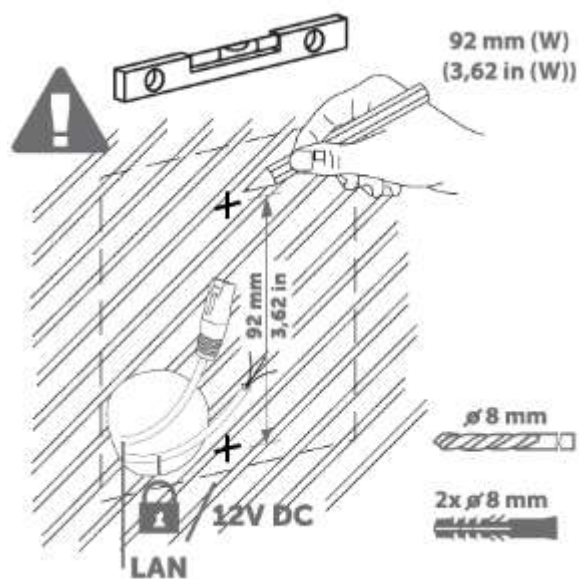

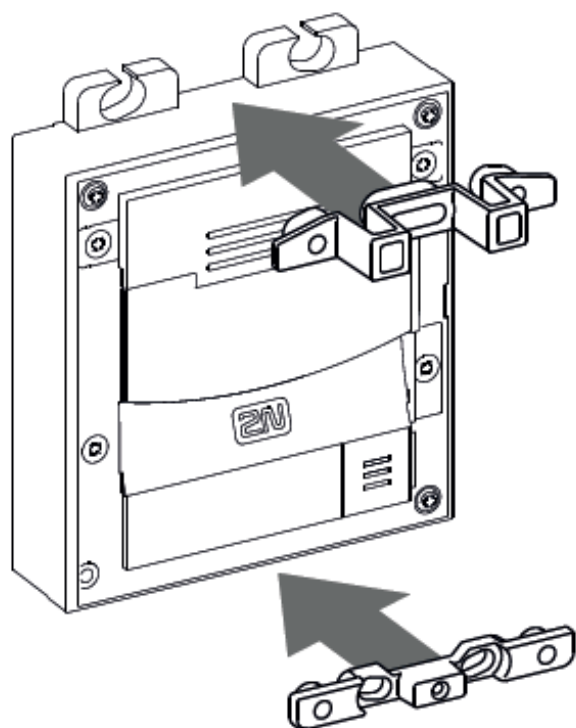
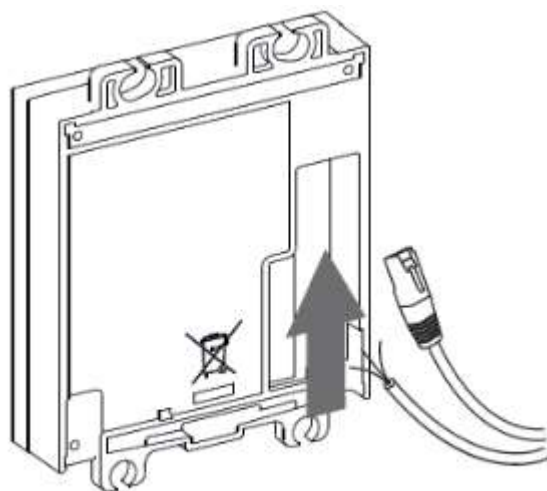

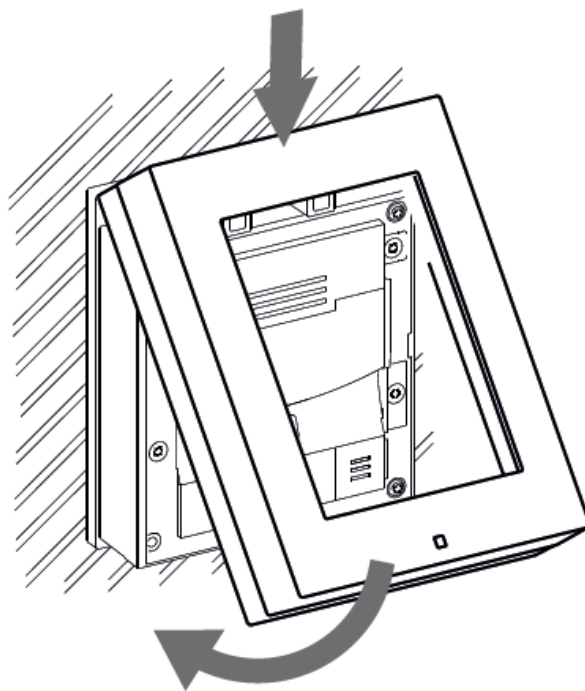
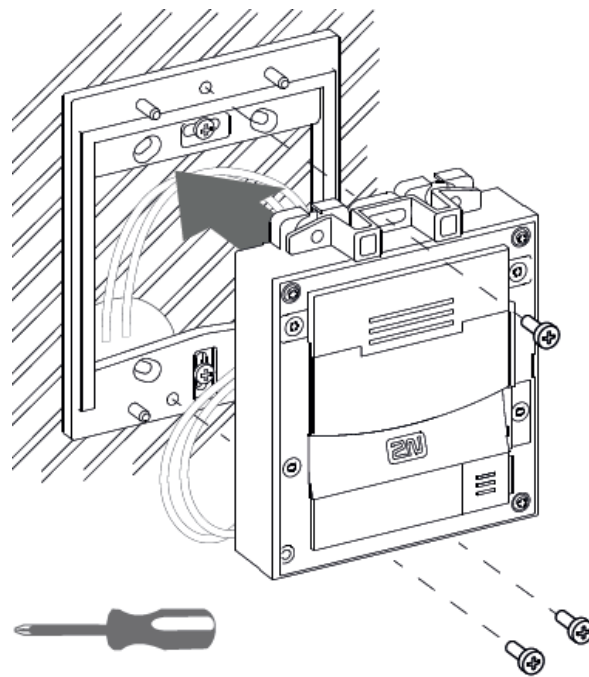

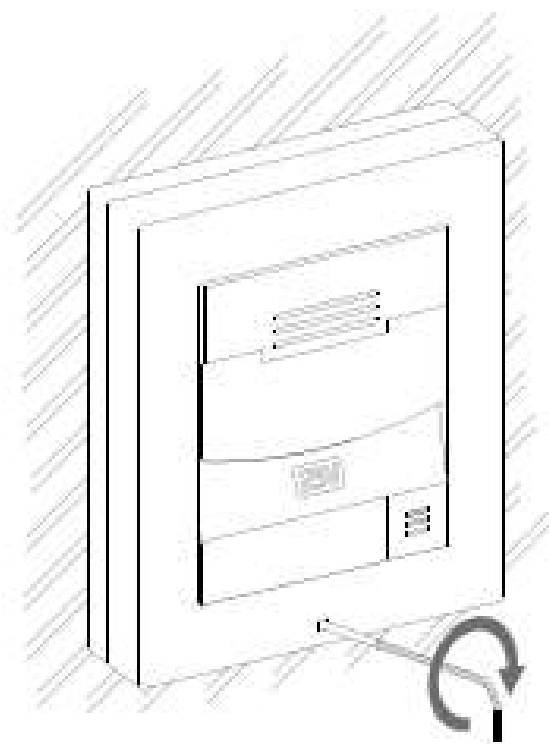

2.3 Electric Installation

This subsection describes how to install the modules, how to connect the 2N[®] IP Solo main unit to the power supply and LAN and how to connect other elements.

Caution

- The device must be part of the electrical system of the building.

Mounting Preparation

1. Place the 2N[®] IP Solo on the flush mounting box / pre-drilled holes with dowels and pull the cables through the bottom holes. Pull the Ethernet cable through the bottom hole to the left if necessary.
2. Insert the metal fitting elements up and down and screw the access unit tight. You can level the unit slightly in this mounting type.

Main Unit

Power Supply Connection

2N[®] IP Solo can be powered either from an external 12 V / 2 A DC source or directly from the LAN equipped with PoE 802.3af supporting network elements.

External power supply

Use a 12 V $\pm 15\%$ SELV supply dimensioned to the minimum current consumption of 2 A (Part No. 91341481E) to make your system work reliably.

PoE Power Supply

2N[®] IP Solo is compatible with the PoE 802.3af (Class 0–12,95 W) technology and can be fed directly from the LAN via the compatible network elements. If your LAN does not support this technology, insert a PoE injector, Part No. 91378100, between 2N[®] IP Solo and the nearest network element.

Combined Power Supply

2N[®] IP Solo can be fed from an external power supply and PoE at the same time. In this configuration, the maximum power for the connected modules is available.

LAN Connection

2N[®] IP Solo is connected to the Local Area Network (LAN) via the UTP/STP cable (Cat 5e or higher) terminated with an RJ-45 (LAN) connector. As the device is equipped with the Auto-MDIX function, both the straight and crossed cable can be used.

Caution

- We recommend the use of a LAN surge protection.
- We recommend the use of a shielded SSTP Ethernet cable with a shielded RJ-45 connector connected to the switch (with the grounding option) via the same shielded connector. This makes the device perfectly grounded.

	Basic Unit with Camera (HW version 3)		Basic Unit without Camera (HW version 3)	
	mA	W	mA	W
12 V				
At relax	200	2.4	200	1.8
Infrared illumination	158	1.9	-	-
LED - call	7	0.08	7	0.8
LED - ringing	5	0.06	5	0.06

	Basic Unit with Camera (HW version 3)		Basic Unit without Camera (HW version 3)	
LED - lock	4	0.048	4	0.048
LED - allowed access	5	0.048	5	0.048
Button backlight	4	0.048	4	0.048
Name tag backlight	4	0.048	4	0.048
Unit backlight	14	0.168	14	0.168
Relay 1	16	0.2	16	0.2
OUT 1	400	4.8	400	4.8
Audio	213	2.556 *power output of 2 W / 4 ohm	213	2.556 *power output of 2 W / 4 ohm
Total	1.030 [A]	12.368 [W]	872 [A]	10.464 [W]

Main Unit Connector Configuration

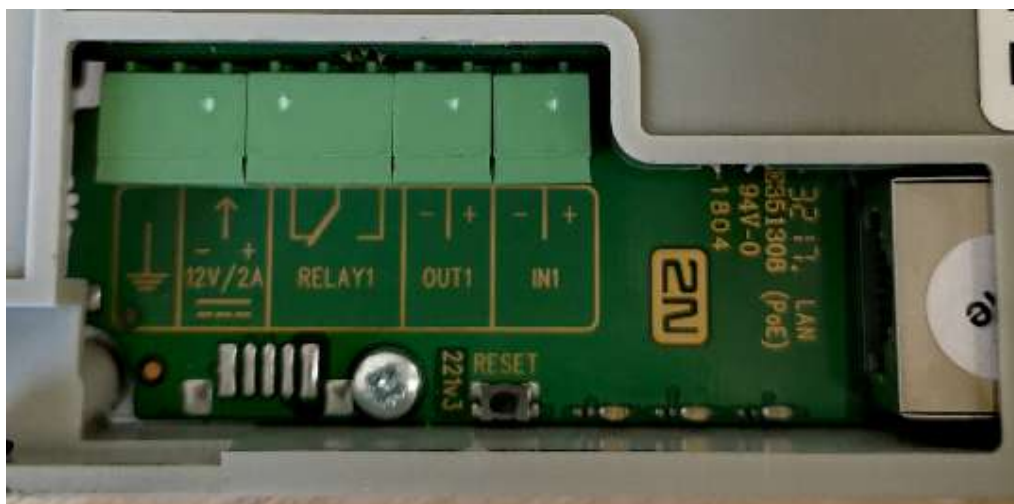

Legend	
LAN (PoE)	LAN (PoE according to 802.1af) connector
IN1	IN1 terminals for input in passive/ active mode (-30 V to $+30\text{ V}$ DC) OFF = open OR $U_{IN} > 1.5\text{ V}$ ON = closed contact OR $U_{IN} < 1.5\text{ V}$
OUT1	OUT1 terminals of active input for 2N[®] Security Relay or electric lock connection 8 up to 12 V DC depending on power supply (PoE: 10 V ; adaptor: power supply voltage minus 2 V), max. 600 mA
RELAY1	RELAY1 terminals with accessible $30\text{ V} / 1\text{ A}$ AC/DC NO/NC contact. Used for connection of non-critical devices only (lights, e.g.).
12V/2A	External $12\text{ V} / 2\text{ A}$ DC supply terminals
GND	Grounding terminal
RESET	RESET / FACTORY RESET button

Tip

- Output wiring diagram for Relay terminals

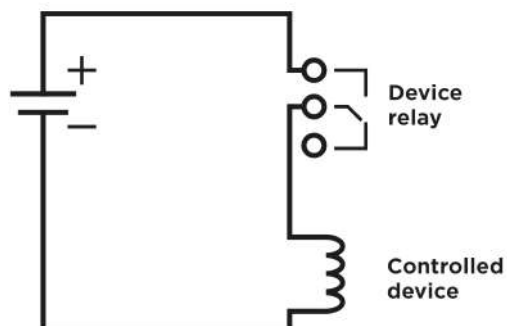

Wiring diagram for the controlled device's electric circuit closing

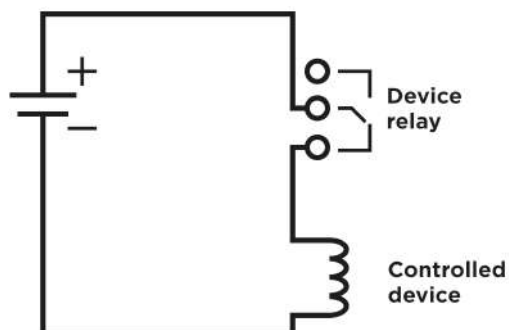

Wiring diagram for the controlled device's electric circuit opening

Tip

- Wiring Diagram of IN1 connector in active mode

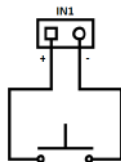

- Wiring Diagram of IN1 connector in passive mode

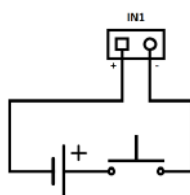

Reset Button

Located among the main unit connectors, the Reset button helps you reset the factory default values, restart the device, find the device IP address and switch the static /dynamic mode.

IP Address Finding

Follow the instructions below to **identify the current IP address**:

- Press and hold the RESET button.
- Wait until the red and green LEDs go on simultaneously on the device and the acoustic signal  can be heard (approx. 15–35 s).
- Release the RESET button.
- The device automatically announces the current IP address.

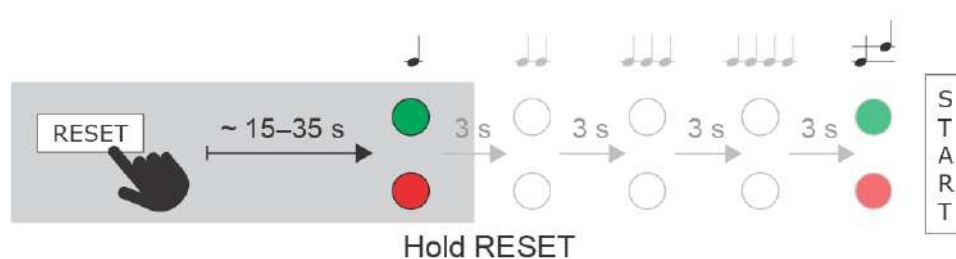

Note

- The delay after pressing RESET till the first light and sound signalling is set to 15–35 s depending on the 2N IP intercom/answering unit model used.
 - 18 s is the valid value for 2N[®] IP Solo.





Static IP Address Setting

Follow the instructions below to switch on the **Static IP address** mode (DHCP OFF):

- Press and hold the RESET button.
- Wait until the red and green LEDs go on simultaneously on the device and the acoustic signal  can be heard (approx. 15–35 s).

Factory Reset

Follow the instructions below to **reset the factory default values**:

- Press and hold the RESET button.
- Wait until the red and green LEDs go on simultaneously and the acoustic signal  can be heard (approx. 15–35 s).
- Wait until the red LED goes off and the acoustic signal  can be heard (approx. for another 3 s).
- Wait until the green LED goes off and the red LED goes on again and the acoustic signal  can be heard (approx. for another 3 s).
- Wait until the red LED goes off and the acoustic signal  can be heard (approx. for another 3 s).
- Release the RESET button.

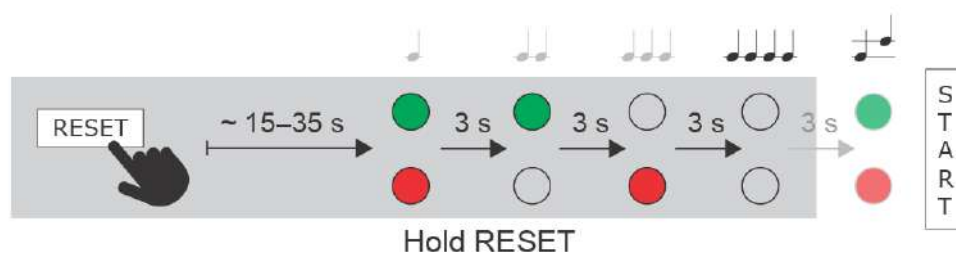

Caution

- In case of resetting the factory default settings on a device with a version of firmware 2.18 or higher it is necessary to reprogram the 2N[®] Security Relay using the instructions from section 2.4.

Device Restart

Press the RESET button shortly (< 1 s) to restart the system without changing configuration.

Note

- The time interval between the short press of RESET and reconnection after restart is 26 s for 2N[®] IP Solo.

Available Outputs

Location	Name	Description
Main Unit	Relay 1	Passive switch: NO/NC contact, up to 30 V / 1 A AC/DC. Used for connection of non-critical devices only (lights, e.g.).
	Output 1	Active switch output: 8 up to 12 V DC depending on power supply (PoE: 10 V; adaptor: power supply voltage minus 2 V), max. 600 mA

Warning

When you connect a device containing a coil, such as a relay or an electromagnetic lock, it is necessary to protect the intercom against voltage peak while switching off the induction load. For this way of protection we recommend a diode 1 A / 1000 V (e.g., 1N4007, 1N5407, 1N5408) connected antiparallel to the device.

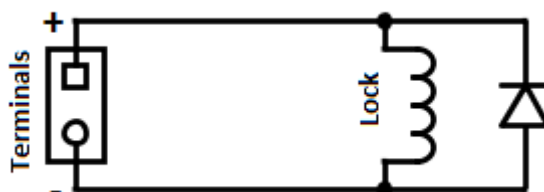

Main Unit LED Pictograms



Main Unit LED Pictogram Layout

2.3.1 Overvoltage Protection

Recommendations for Additional Overvoltage Protection Installation

If running:

- a) outside a building,
- b) on/in an outer wall or roof,

the 2N device wiring may be exposed to atmospheric effects resulting in overvoltage that may subsequently damage any devices installed outside the building, on its outer wall or roof. Overvoltage may damage devices connected to these wires and installed inside the building as well. Therefore, we recommend that additional surge protectors be installed on all the wires leading outside buildings, on outer walls or roofs, namely:

- a) as close as possible to the device installed outside the building or on its outer wall /roof,
- b) as close as possible to the point where the wires leave the building.

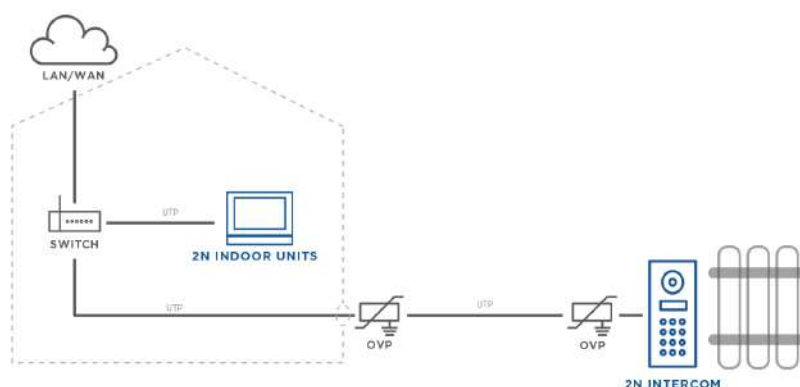
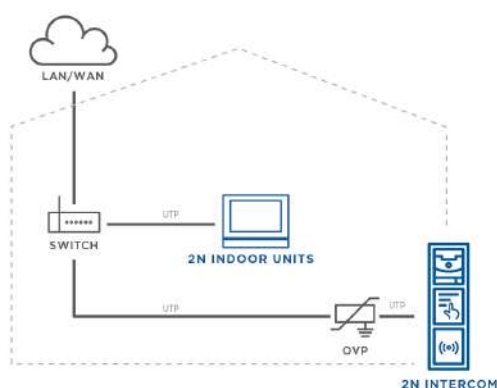

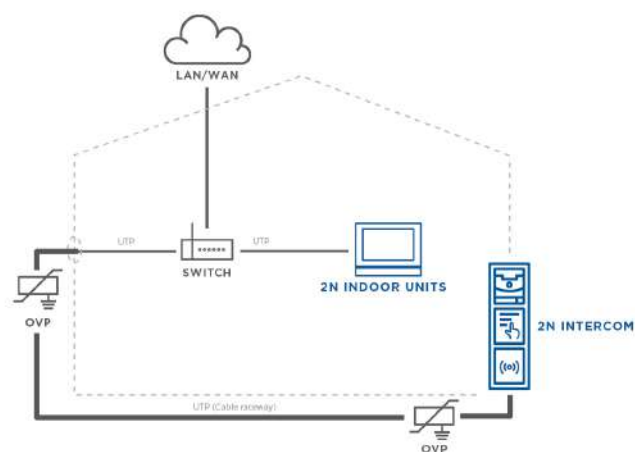

OVP = overvoltage protection

2.4 Extending Module Connection

2N[®] IP Solo allows to connect the following extending modules:

- Security relay

Security Relay

The 2N[®] IP Security Relay (Part No. 9159010) is used for enhancing security between the intercom and the connected electric lock. The 2N[®] IP Intercom Security Relay is designed for any 2N IP intercom model with firmware versions 1.15 and higher. It significantly enhances security of the connected electric lock as it prevents lock opening by forced intercom tampering.



Function:

The 2N[®] IP Intercom Security Relay is a device installed between an intercom (outside the secured area) and the electric lock (inside the secured area). The 2N[®] IP Intercom Security Relay includes a relay that can only be activated if the valid opening code is received from the intercom.

Specifications:

Passive switch: NO and NC contacts, up to 30 V / 1 A AC/DC

Switched output:

- Where the security relay is fed from the intercom, 9 to 13 V DC is available on the output depending on the power supply (PoE: 9 V; adapter: source voltage of minus 1 V) / 400 mA DC.
- Where the security relay is fed from an external power supply, 12 V / 700 mA DC is available on the output.

Dimensions: (56 x 31 x 24) mm

Weight: 20 g

Installation:

Install the 2N[®] IP Intercom Security Relay onto a two-wire cable between the intercom and the electric lock inside the area to be secured (typically behind the door). The device is powered and controlled via this two-wire cable and so can be added to an existing installation. Thanks to its compact dimensions, the device can be installed into a standard mounting box.

Connection:

Connect the 2N[®] IP Intercom Security Relay to the intercom as follows:

- To the intercom active output (OUT1)

Connect the electric lock to the 2N[®] IP Intercom Security Relay output as follows:

- To the switched output.
- To the passive output in series with the external power supply.

The device also supports a Departure button connected between the 'PB' and '- Helios IP/IP Intercom' terminals. Press the Departure button to activate the output for 5 seconds.

Status signalling:

Green LED	Red LED	Status
blinking	off	Operational mode
on	off	Activated output
blinking	blinking	Programming mode - waiting for initialisation
on	blinking	Error - wrong code received

Configuration:

- Connect the 2N[®] IP Intercom Security Relay to the properly set intercom switch output; refer to the **Configuration manual for 2N IP intercoms**. Make sure that one LED at least on the 2N[®] IP intercom Security Relay is on or blinking.
- Press and hold the 2N[®] IP Intercom Security Relay Reset button for 5 seconds to put the device in the programming mode (both the red and green LEDs are blinking).
- Activate the intercom switch using the keypad, telephone, etc. The first code sent from the intercom will be stored in the memory and considered valid. After code initialisation, the 2N[®] IP Intercom Security Relay will pass into the operational mode (the green LED is blinking).



Caution

- In case of resetting the factory default settings on a device with a version of firmware 2.18 or higher it is necessary to reprogram the 2N[®] IP Intercom Security Relay using the instructions above.



Tip

- FAQ: 2N[®] IP Intercom Security Relay – what is it and how to use it with 2N IP intercom?

Connection:

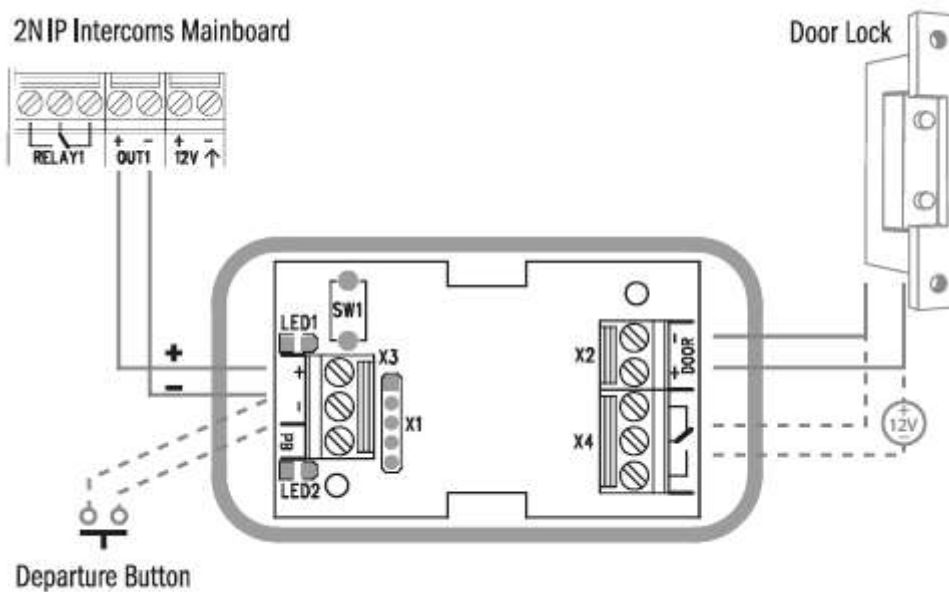

2.5 Completion

Installation Completion

Check the connection of all wires and the RJ-45 plug to the board connector.

Caution

- All unused connectors have to have tightened screws in order to avoid vibration caused by sound.

Nametag Placing

Every intercom package includes a piece of transparent foil, which can be laser printed. Cut the printed foil and insert the nametags in the buttons.

Nametag dimensions for button:

- 1 button: 52.0 (W) x 15.2 (H) mm (dimensional tolerance: +0; -0.5 mm)

Caution

- The area where nametags are placed is called a wet zone. After heavy rain, water can penetrate to the nametag. Water in this area does not affect the intercom functionality in any way and evaporates soon.
- Always use waterproof foil (enclosed or other) for the nametags. Never use paper or ink jet printing to avoid damage due to water leakage!

Nametag inserting/replacing:

1. Remove the frame.
2. Lift up the button door. The 5-button module buttons have just one door.
3. Remove the used nametag and insert a new one.
4. Close the button door.
5. Replace the frame.

Frame Replacement

Check the frame sealing before replacing the frame.

Version A

- Screw the flush mounting frame in the upper and bottom parts.

Version B

- Hang the surface mounting frame on the hook in the upper part and then screw it tight in the bottom part.



Caution

- Improper mounting may deteriorate the intercom waterproofness and water may damage the electronic part.
- Make sure that all holes are filled with some waterproof material - the top part, around the cables and the screws.
- Use silicone or some other sealant to seal the box against the wall if uneven to avoid water leakage and wall damping..

3. Function and Use

This section describes the basic and extending functions of the the 2N[®] IP Solo product.

Here is what you can find in this section:

- **3.1 Configuration**
- **3.2 Intercom Control as Viewed by External User**
- **3.3 Intercom Control as Viewed by Internal User**
- **3.4 Maintenance**
- **3.5 Downloads**

3.1 Configuration

Configure 2N[®] IP Solo using your PC with any internet browser:

- Launch your internet browser (Internet Explorer, Firefox, etc.).
- Enter the IP address of your intercom (<http://192.168.1.100/>, e.g.).
- Log in using the username **Admin** and password **2n**.

You have to know your intercom IP address to log in to the integrated web server.

Upon purchase, 2N[®] IP Solo is set to the dynamic IP address mode – it retrieves the IP address automatically if there is a properly configured DHCP server in the LAN. If no DHCP is available, operate 2N[®] IP Solo in the static IP address mode. Refer to the

Configuration manual for 2N IP intercoms for the 2N[®] IP Solo configuration details.

If your device remains inaccessible (you have forgotten the IP address, the network configuration has changed, etc.), you can change the network configuration using the device buttons.

IP Address Retrieval

Take the following steps to retrieve the 2N[®] IP Solo IP address:

- Connect (or, if connected, disconnect and reconnect) 2N[®] IP Solo to the power supply.
- Wait for the second sound signal .
- Press the quick dial button on the main unit 5 times.
- 2N[®] IP Solo will read its IP address.
- If the address is 0.0.0.0, it means that the intercom has not obtained the IP address from the DHCP server.





Note

- Be sure to press the button sequence within thirty seconds after the sound signal for security reasons. Up to 2 s intervals are allowed between the presses.

Dynamic/Static IP Address Switching

Take the following steps to switch the dynamic and static IP address mode in 2N[®] IP Solo:

- Connect (or, if connected, disconnect and reconnect) 2N[®] IP Solo to the power supply.
- Wait for the first sound signal .
- Press the quick dial button on the main unit 15 times.
- Switching is signalled with the sound signal .
- Wait until the device is restarted automatically.
- Upon restart, the static IP address mode will be switched to the dynamic IP address mode and vice versa.



The following network parameters will be set after the static IP address mode is switched on and the device is restarted:

- IP address: 192.168.1.100
- Network mask: 255.255.255.0
- Default gateway: 192.168.1.1

Note

- Be sure to press the button sequence within thirty seconds after the sound signal for security reasons. Up to 2 s intervals are allowed between the presses.

3.2 Intercom Control as Viewed by External User

Quick Dial Buttons

Press the quick dial button on the main unit to dial the first position in the phone directory (Phone Book).

By pressing the quick dial buttons you dial the phone numbers assigned to the particular Phone Book position. Call setup is signalled by a long intermittent or any other tone depending on the configuration of the PBX connected.

Repeated pressing of one and the same quick dial button during call setup may initiate call hangup or call termination plus dialling the next phone number of the called subscriber, or may be assigned no function; refer to the Intercom Configuration / Hardware / Keyboard subsection of Configuration Manual.

Calling to Phone Book Position

The 2N[®] IP Solo Phone Book can contain up to 1999 programmable positions.

3.3 Intercom Control as Viewed by Internal User

Call Answering

You can answer the incoming calls to the 2N[®] IP Solo intercom using your phone like any other calls. You can unlock the door, activate/deactivate a user/profile via your phone keypad during the call. The calls, however, are time-limited to avoid unintentional blocking of the 2N[®] IP Solo line. Set the maximum call duration in the **Call time limit** (refer to the Intercom Configuration / Services / Phone / Calls subsection of Configuration Manual). Press # on your phone anytime to extend the call time. The automatic call termination is signalled with a short beep 10 s before the call end.



Calling to 2N[®] IP Solo

2N[®] IP Solo allows you to answer incoming calls. Set the required parameters in the Incoming calls group; refer to the Intercom Configuration / Services / Phone / Calls subsection of Configuration Manual.

Door Opening (Switch Activation) by Code

2N[®] IP Solo is equipped with a door unlocking switch. Enter the valid code (refer to the Intercom Configuration / Hardware / Switches subsection of Configuration Manual) using your phone keypad to activate this switch.

Procedure:

- Enter the switch 1 or 2 activating code using your phone keypad and press  for confirmation. Confirmation is unnecessary if the **Lock code without confirmation** is enabled, refer to the Intercom Configuration / Hardware / Switches / Advanced subsection of Configuration Manual.
- A valid code is signalled by the  sound. An invalid code or interruption longer than as defined in **Timeout for Entering Numbers** is signalled by the  sound.

3.4 Maintenance

Cleaning

If used frequently, the device surface, the keypad in particular, gets dirty. To clean it, use a piece of soft cloth moistened with clean water. We recommend you to follow these principles while cleaning:

- Never use aggressive detergents (such as abrasives or strong disinfectants).
- Use suitable cleaning agents for glass lens cleaning (cleaners for glasses, optic devices screens, etc.)
- Clean the device in dry weather in order to make waste water evaporate quickly.

Warning

- Prevent water from getting inside the intercom.
- Do not use alcohol-based cleaners.
- Avoid peroxide-based cleaners.

3.5 Downloads

Templates

Nameplates

Software

2N[®] IP Eye

2N[®] Network Scanner

4. Technical Parameters

Signalling protocol

- SIP (UDP, TCP, TLS)

Buttons

- **Button design:** white-backlit transparent button with replaceable nametags
- **Button count:** 1

Audio

- **Microphone:** 1 integrated microphone
- **Amplifier:** 2 W (class D) amplifier
- **Speaker:** 2 W / 8 Ω
- **Sound pressure level (SPL max):** 71 dB (for 1 kHz, distance 1 m)
- **Output LINE OUT:** 1 VRMS / 600 Ω
- **Volume control:** adjustable with automatic adaptive mode
- **Full duplex:** yes (AEC)
- **Speech transmission index (STI):** 0.89

Audio stream

- **Protocols:** RTP / RTSP
- **Codecs:** G.711, G.729, G.722, L16/16 kHz

Camera

- **Sensor:** 1/3" colour CMOS
- **JPEG resolution:** up to 1280 (H) x 960 (V)
- **Video resolution:** 640 (H) x 480 (V)
- **Frame rate:** up to 30 snapshots/s
- **Sensor sensitivity:** 5.6 V/lux-sec (550 nm)
- **View angle:** 128 ° (H), 95 ° (V), 134 ° (D)
- **Infrared light:** yes
- **Sensor sensitivity without IR light:** 0,1 Lux ± 20 %
- **Focal length:** 2.25 mm

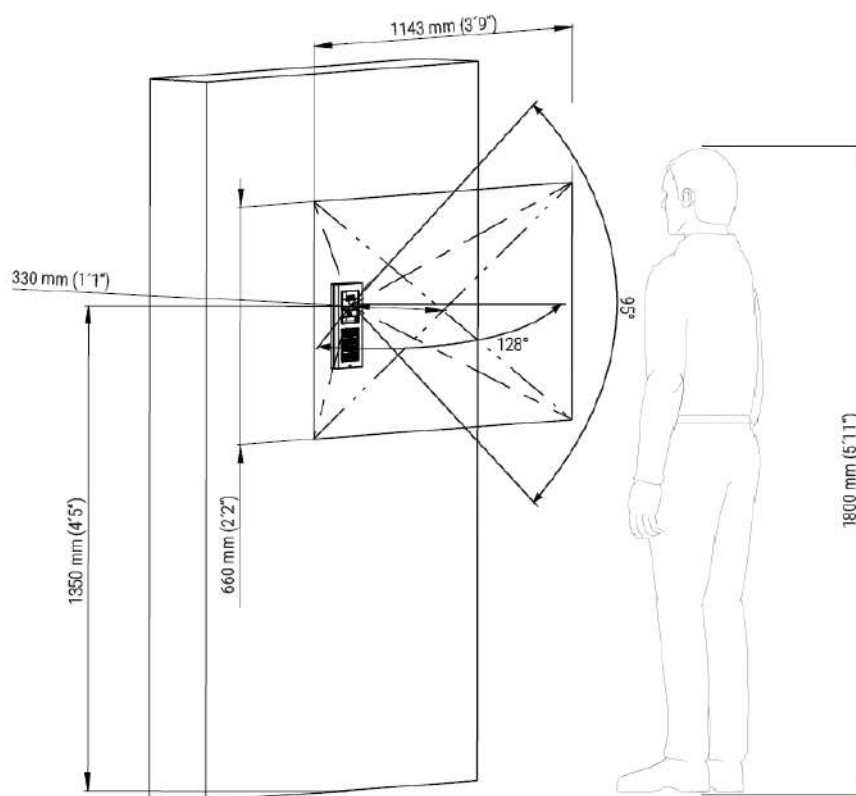

Video stream

- **Protocols:** RTP / RTSP / HTTP
- **Codecs:** H.263, H.263+, H.264, MPEG-4, M-JPEG
- **IP camera function:** yes, ONVIF v2.4 profile S compatible

Bandwidth

- **Audio codecs**

- PCMA, PCMU – 64 kbps (with 85.6 kbps headers)
- G.729 – 16 kbps (with 29.6 kbps headers)
- G.722 – 64 kbps (with 85.6 kbps headers)
- L16 / 16 kHz – 256 kbps (with 277.6 kbps headers)

- **V i d e o c o d e c s**

Set the video codec data flows in the Services / Phone / Video menu for calls and in the Services / Streaming / RTSP menu for streaming. The set bandwidth represents the value that the codec has to approach on a long-time average. The data flows can vary depending on the scene to be scanned.

The measured data flow values correspond to the test view of a person standing in front of the intercom.

- **H.264**

- Low quality: QVGA (320 x 240), 10 fps, 256 kbps: 181 kbps (with 190 kbps headers)
- Medium quality: VGA (640 x 480), 15 fps, 768 kbps: 600 kbps (with 661 kbps headers)
- High quality: VGA (640 x 480), 30 fps, 2048 kbps: 1319 kbps (with 1372 kbps headers)

- **MJPEG**

- Low quality: QVGA (320 x 240), 10 fps, quality 70: 435 kbps with headers
- Medium quality: VGA (640 x 480), 15 fps, quality 85: 506 kbps
- High quality: SXGA (1280 x 960), 15 fps, quality 95: 8 Mbps

Interface

- **Power supply:** 12 V \pm 15 % / 2 A DC or PoE
- **PoE:** PoE 802.3af (Class 0–12.95 W)
- **LAN:** 10/100BASE-TX with Auto-MDIX, RJ-45
- **Recommended cabling:** Cat-5e or higher
- **Supported protocols:** SIP2.0, DHCP opt. 66, SMTP, 802.1x, RTSP, RTP, TFTP, HTTP, HTTPS, Syslog, ONVIF
- **Passive switch:** NO/NC contact, up to 30 V / 1 A AC/DC
- **Active switch output:** 8 up to 12 V DC depending on power supply (PoE: 10 V; adaptor: power supply voltage minus 2 V), max. 600 mA
- **Tamper switch** is part of the 2N[®] IP Solo

Mechanical properties

- **Cover:** robust zinc casting with surface finish (minor surface shade nuances are acceptable)
 - **91550XX - NICKEL**
 - Material - Zamak 410 - Zn95Al4Cu1
 - Surface treatment - Zn/Cu20/Ni25b max. 80 µm
 - **91550XXB - BLACK**
 - Material - Zamak 410 - Zn95Al4Cu1
 - Surface treatment - PUR Wet coating 15-25 µm, RAL 9005 Jet black
 - interior side - passivated zinc
- **Working temperature:** -40 °C - 60 °C
- **Working relative humidity:** 10 % - 95 % (non-condensing)
- **Storing temperature:** -40 °C - 70 °C
- **Dimensions**
 - **Surface mounting frame:**
 - 107 (W) x 130 (H) x 28 (D) mm
 - 4.21 (W) x 5.12 (H) x 1.10 (D) inches
 - **Flush mounting frame:**
 - 130 (W) x 153 (H) x 5 (D) mm
 - 5.12 (W) x 6.02 (H) x 0.20 (D) inches
 - **Flush mounting box (minimum hole dimensions):**
 - 108 (W) x 131 (H) x 45 (D) mm
 - 4.25 (W) x 5.16 (H) x 1.77 (D) inches
 - **Module internal cutout:** 72 (W) x 89,3 (H) mm / 2.83 (W) x 3.51 (H) inches
- **Weight:** max net weight: 1 kg
- **Covering level:** IP54
- **Resistance level:** IK08

4.1 General drawings

Surface mounting

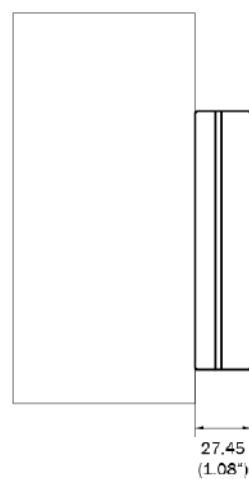
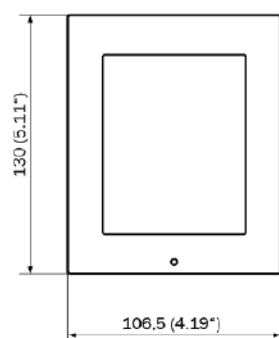

Flush mounting

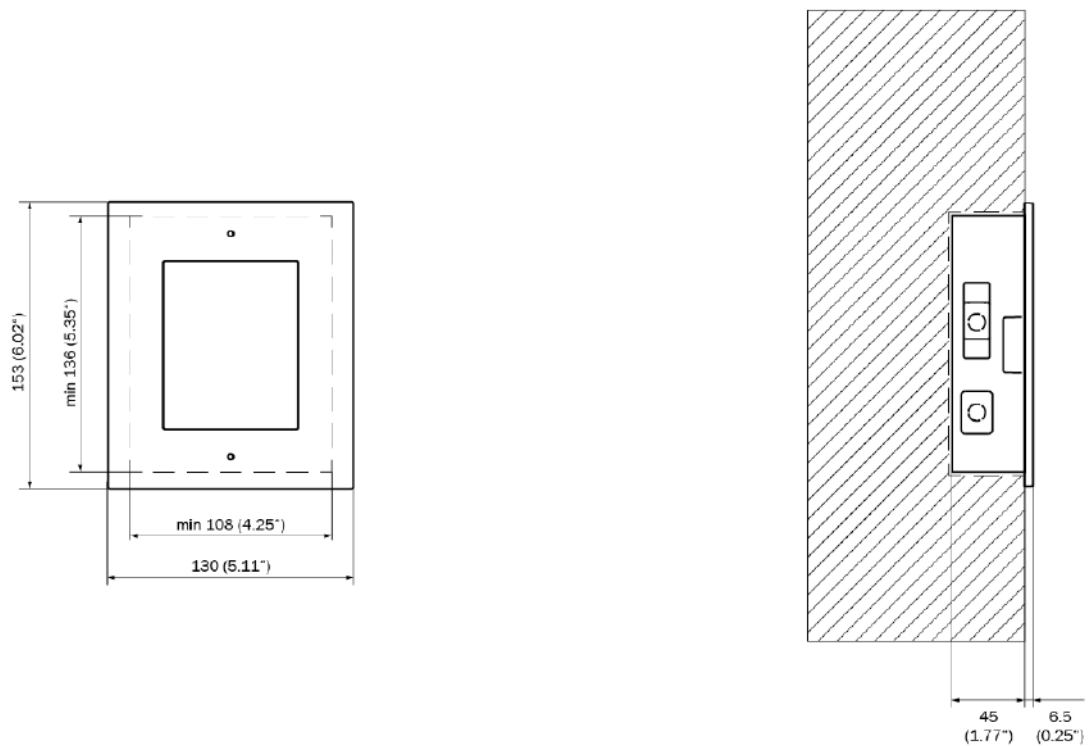

5. Supplementary Information

Here is what you can find in this section:

- 5.1 Troubleshooting
- 5.2 Directives, Laws and Regulations
- 5.3 General Instructions and Cautions

5.1 Troubleshooting



For the most frequently asked questions refer to faq.2n.cz.

5.2 Directives, Laws and Regulations

2N[®] IP Solo conforms to the following directives and regulations:

- 2014/35/EU for electrical equipment designed for use within certain voltage limits
- 2014/30/EU for electromagnetic compatibility
- 2011/65/EU on the restriction of the use of certain hazardous substances in electrical and electronic equipment
- 2012/19/EU on waste electrical and electronic equipment

Industry Canada

This Class B digital apparatus complies with Canadian ICES-003/NMB-003.

FCC

This equipment has been tested and found to comply with the limits for a Class B digital device, pursuant to part 15 of the FCC Rules.

NOTE: These limits are designed to provide reasonable protection against harmful interference in a residential installation. This equipment generates, uses and can radiate radio frequency energy and, if not installed and used in accordance with the instructions, may cause harmful interference to radio communications.

However, there is no guarantee that interference will not occur in a particular installation. If this equipment does cause harmful interference to radio or television reception, which can be determined by turning the equipment off and on, the user is encouraged to try to correct the interference by one or more of the following measures:

- Reorient or relocate the receiving antenna
- Increase the separation between the equipment and receiver
- Connect the equipment into an outlet on a circuit different from that to which the receiver is connected
- Consult the dealer or an experienced radio/TV technician for help

Changes or modifications to this unit not expressly approved by the party responsible for compliance could void the user's authority to operate this equipment.

 **Caution****Warning**

In order to ensure the full functioning and guaranteed outputs we strongly recommend a verification of the timeliness of version of product or facility already during the installation process. The customer takes into consideration that the product or facility can achieve the guaranteed outputs and be fully operational pursuant to the producer's instructions only by using the most recent version of product or facility, which has been tested for full interoperability and has not been determined by the producer as incompatible with certain versions of other products, only in conformity with the producer's instructions, guidelines, manual or recommendation and only in conjunction with suitable products and facilities of the other producers. The most recent versions are available on the website https://www.2n.cz/cs_CZ/, or specific facilities, depending on their technical capacity, allow updating in the configuration interface. Should the customer use any other version of product or facility than the most recent one, or the version that has been determined by the producer as incompatible with certain versions of other producers' products of facilities, or the product or facility in a way incompatible with the producer's instructions, guidelines, manual or recommendation or in conjunction with unsuitable products or facilities of the other producers, he or she is aware of all potential limitations of functionality of such a product or facility and all relating consequences. Should the customer use any other than the most recent version of the product or facility, or the version that has been determined by the producer as incompatible with certain versions of other producers' products of facilities, or the product or facility in a way incompatible with the producer's instructions, guidelines, manual or recommendation or in conjunction with unsuitable products or facilities of the other producers, he or she agrees that the company 2N TELEKOMUNIKACE a. s. is not liable neither for any limitation of such a product's functionality, nor for any damage, loss or injury relating to such a potential limitation of functionality.

5.3 General Instructions and Cautions

Please read this User Manual carefully before using the product. Follow all instructions and recommendations included herein.

Any use of the product that is in contradiction with the instructions provided herein may result in malfunction, damage or destruction of the product.

The manufacturer shall not be liable and responsible for any damage incurred as a result of a use of the product other than that included herein, namely undue application and disobedience of the recommendations and warnings in contradiction herewith.

Any use or connection of the product other than those included herein shall be considered undue and the manufacturer shall not be liable for any consequences arisen as a result of such misconduct.

Moreover, the manufacturer shall not be liable for any damage or destruction of the product incurred as a result of misplacement, incompetent installation and/or undue operation and use of the product in contradiction herewith.

The manufacturer assumes no responsibility for any malfunction, damage or destruction of the product caused by incompetent replacement of parts or due to the use of reproduction parts or components.

The manufacturer shall not be liable and responsible for any loss or damage incurred as a result of a natural disaster or any other unfavourable natural condition.

The manufacturer shall not be held liable for any damage of the product arising during the shipping thereof.

The manufacturer shall not make any warrant with regard to data loss or damage.

The manufacturer shall not be liable and responsible for any direct or indirect damage incurred as a result of a use of the product in contradiction herewith or a failure of the product due to a use in contradiction herewith.

All applicable legal regulations concerning the product installation and use as well as provisions of technical standards on electric installations have to be obeyed. The manufacturer shall not be liable and responsible for damage or destruction of the product or damage incurred by the consumer in case the product is used and handled contrary to the said regulations and provisions.

The consumer shall, at its own expense, obtain software protection of the product. The manufacturer shall not be held liable and responsible for any damage incurred as a result of the use of deficient or substandard security software.

The consumer shall, without delay, change the access password for the product after installation. The manufacturer shall not be held liable or responsible for any damage incurred by the consumer in connection with the use of the original password.

The manufacturer also assumes no responsibility for additional costs incurred by the consumer as a result of making calls using a line with an increased tariff.

Electric Waste and Used Battery Pack Handling



Do not place used electric devices and battery packs into municipal waste containers. An undue disposal thereof might impair the environment!

Deliver your expired electric appliances and battery packs removed from them to dedicated dumpsites or containers or give them back to the dealer or manufacturer for environmental-friendly disposal. The dealer or manufacturer shall take the product back free of charge and without requiring another purchase. Make sure that the devices to be disposed of are complete.

Do not throw battery packs into fire. Battery packs may not be taken into parts or short-circuited either.



2N TELEKOMUNIKACE a.s.

Modřanská 621, 143 01 Prague 4, Czech Republic

Phone: +420 261 301 500, Fax: +420 261 301 599

E-mail: sales@2n.cz

Web: www.2n.cz

v2.16